

Platform lowlifter truck 2.0 - 2.5 ton

P320

P322

P325

P300 Series



Platform lowlifter

IDENTIFICATION			P320		P322		P325	
1.1	Manufacturer		CESAB	CESAB	CESAB	CESAB	CESAB	
1.2	Model		P320	P320	P320	P322	P325	
1.3	Drive		Electric	Electric	Electric	Electric	Electric	
1.4	Operator type		Stand on/pedestrian					
1.5	Load capacity/rated load	Q kg	2000	2000	2000	2200	2200	2500
1.6	Load centre	c mm	600	600	600	600	600	600
1.8	Load distance, centre of support arm wheel to face of fork, fork raised/lowered	x mm	913/957*	913/957*	913/957*	913/957*	913/957*	913/957*
1.9	Wheelbase, fork raised/lowered	y mm	1362/1406*	1362/1406*	1362/1406*	1410/1454*	1410/1454*	1410/1454*
WEIGHT								
2.1	Service weight with battery	kg	718	718	718	826	826	826
2.2	Axle load, with load, drive/castor/fork wheel	kg	466/585/1667	466/585/1667	466/585/1667	679/834/1513	679/834/1513	641/911/1774
2.3	Axle load, without load, drive/castor/fork wheel	kg	284/294/140	284/294/140	284/294/140	389/311/126	389/311/126	389/311/126
WHEELS								
3.1	Drive/castor/fork wheel		Polyurethane					
3.2	Wheel size, front	mm	Ø 230x70	Ø 230x70	Ø 230x82	Ø 230x70	Ø 230x82	Ø 250x75*
3.3	Wheel size, rear	mm	Ø 85x95	Ø 85x95	Ø 85x95	Ø 85x95	Ø 85x95	Ø 85x95
3.4	Additional wheels (dimensions)	mm	Ø 125x50*	Ø 125x50*	Ø 125x50*	Ø 125x50*	Ø 125x50*	Ø 150x54*
3.5	Wheels, number front/rear (x = driven wheels)		1x+ 2 or 4/2 or 4			1x+ 2 or 4/2 or 4		1x+2 or 4/2 or 4
3.6	Track width, front	b ₁₀ mm	500	500	500	500	500	500
3.7	Track width, rear	b ₁₁ mm	370	370	370	370	370	370
DIMENSIONS								
4.4	Lift	h ₃ mm	120 ¹⁾	120 ¹⁾	120 ¹⁾	120 ¹⁾	120 ¹⁾	120 ¹⁾
	Lift height	h ₂₃ mm	205 ¹⁾	205 ¹⁾	205 ¹⁾	205 ¹⁾	205 ¹⁾	205 ¹⁾
4.8	Stand height	h ₇ mm	190	190	190	190	190	190
	Height of tiller in drive position, min./max.							
4.9	Manual steering	h ₁₄ mm	1100/1413	1100/1413	1100/1413	1100/1413	1100/1413	1100/1413
	Power steering, highest setting	h ₁₄ mm	1201/1413	1201/1413	1201/1413	1201/1413	1201/1413	1201/1413
	Power steering, lowest setting	h ₁₄ mm	1101/1313	1101/1313	1101/1313	1101/1313	1101/1313	1101/1313
4.15	Height, fork lowered	h ₁₃ mm	85	85	85	85	85	85
4.19	Overall length	l ₁ mm	1816*	1816*	1816*	1864*	1864*	1864*
4.20	Length to face of forks	l ₂ mm	666*	666*	666*	714*	714*	714*
4.21	Overall width	b ₁ mm	730	730	730	730	730	730
4.22	Fork dimensions	s/e/l mm	78/180/1150*	78/180/1150*	78/180/1150*	78/180/1150*	78/180/1150*	78/180/1150*
4.25	Width over forks	b ₅ mm	550*	550*	550*	550*	550*	550*
4.32	Ground clearance, centre of wheelbase	m ₁ mm	30	30	30	30	30	30
4.33	Aisle width for pallets 1000x1200 crossways	A _{st} mm	2430*	2430*	2430*	2477*	2477*	2477*
4.34	Aisle width for pallets 800x1200 lengthways	A _{st} mm	2277*	2277*	2277*	2324*	2324*	2324*
4.35	Turning radius, fork raised	W _a mm	1585*	1585*	1585*	1632*	1632*	1632*
PERFORMANCE DATA								
	Travel speed, with/without load							
5.1	Manual steering	km/h	6,0/6,0	8,0/8,0	8,0/10,0	7,5/8,0	7,5/10,0	7,0/12,5
	Power steering	km/h	6,0/6,0	8,0/8,0	9,0/10,0	8,0/8,0/8	9,0/10,0	11,0/12,5
5.2	Lift speed, with/without load	m/s	0,05/0,08	0,05/0,08	0,05/0,08	0,05/0,07	0,05/0,07	0,05/0,07
5.3	Lowering speed, with/without load	m/s	0,11/0,09	0,11/0,09	0,11/0,09	0,11/0,08	0,11/0,08	0,09/0,09
5.8	Max. gradeability, with/without load ²⁾	%	8/18	8/18	8/18	8/18	8/18	8/18
5.9	Acceleration time (over 10 m)	s	5,7	5,7	5,7	5,0	5,0	4,7
5.10	Service brake		Electromagnetic					
ELECTRIC MOTOR								
6.1	Drive motor rating S2 60 min	kW	1,8	2,5	2,5	2,5	2,5	2,8
6.2	Lift motor rating at S3 10%	kW	2,2	2,2	2,2	2,2	2,2	2,2
6.4	Battery voltage/nominal capacity K5	V/Ah	24/300*	24/300*	24/300*	24/400*	24/400*	24/400*
6.5	Battery weight	kg	241	241	241	305	305	305
6.6	Energy consumption acc. to EN16796	kWh/h	0.39	0.39	0.39	0.44	0.44	0.47
OTHERS								
8.1	Type of drive control		Variable AC	Variable AC	Variable AC	Variable AC	Variable AC	Variable AC
8.4	Sound level at the driver's ear according to EN 12 053	dB(A)	60	60	60	60	60	59

Battery dependent dimensions

DIMENSIONS		Battery change		Lift out			Sideways			Li-ion	
		Compartment		Small	Medium	Large/DIN	Small	Medium	Large/DIN	Small	Medium
1.9	Wheelbase, fork raised/lowered	y	mm	1406/1362	1454/1410	1551/1507	1466/1422	1514/1470	1608/1564	1406/1362	1454/1410
4.19	Overall length										
	with platform up/down	l_1	mm	1816/2266	1864/2314	1961/2411	1876/2326	1924/2374	2021/2471	1816/2266	1864/2314
	with backrest	l_1	mm	2440	2488	2585	2500	2548	2645	2440	2488
	with fixed side protection	l_1	mm	2276	2324	2420	2336	2384	2480	2276	2324
4.20	Length to face of forks										
	with platform up/down	l_2	mm	666/1116	714/1164	811/1261	726/1176	774/1224	871/1321	666/1116	714/1164
	with backrest	l_2	mm	1290	1338	1435	1350	1398	1495	1290	1338
	with fixed side protection	l_2	mm	1126	1174	1270	1186	1234	1330	1126	1174
4.33	Aisle width for pallets 1000x1200 crossways										
	with platform up/down	A_{st}	mm	2430/2894	2477/2942	2572/3038	2489/2953	2536/3001	2631/3097	2430/2894	2477/2942
	with backrest	A_{st}	mm	3066	3114	3210	3126	3174	3270	3066	3114
	with fixed side protection	A_{st}	mm	2904	2951	3047	2963	3011	3106	2904	2951
4.34	Aisle width for pallets 800x1200 lengthways										
	with platform up/down	A_{st}	mm	2277/2741	2324/2789	2419/2885	2336/2801	2383/2848	2478/2944	2277/2741	2324/2789
	with backrest	A_{st}	mm	2914	2961	3058	2973	3021	3117	2914	2961
	with fixed side protection	A_{st}	mm	2751	2799	2894	2811	2858	2953	2751	2799
4.35	Turning radius, fork raised										
	with platform up/down	W_a	mm	1585/2049	1632/2096	1727/2193	1644/2108	1691/2156	1786/2252	1585/2049	1632/2096
	with backrest	W_a	mm	2221	2269	2365	2281	2329	2425	2221	2269
	with fixed side protection	W_a	mm	2059	2106	2202	2118	2166	2261	2059	2106
6.4	Battery voltage, nominal capacity K_5	V/Ah		24/225-300	24/400	24/375-600	24/225-300	24/400	24/375-600	24/210	24/300
6.5	Battery weight	kg		175-285	265-350	345-485	175-285	265-350	345-485	206	272 249

1) +20 mm for roll container handling.

2) Measured according to company standard.

*) Further alternatives are available and will produce other values.

All data are based on table configuration. Other configurations may give other values.

Truck performance and dimensions are nominal and subject to tolerances.

CESAB products and specifications are subject to change without notice.

Dimensional drawings

P300 Series

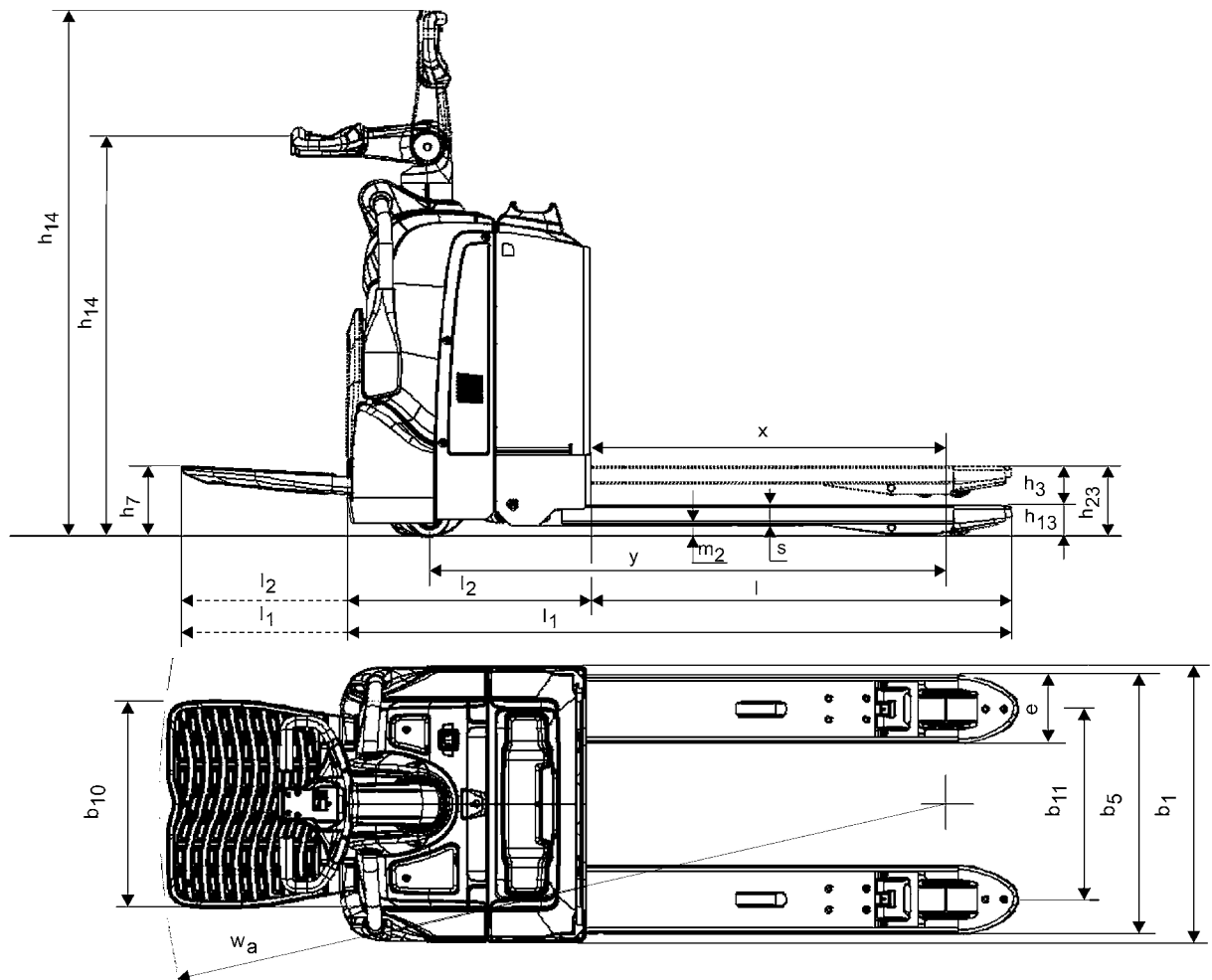

Truck features

- **CESAB** Powertrak traction system
- Fingertip controls
- Information display
- Electronic braking system
- Electronic regenerative brakes
- Driver detection system
- Sideways battery change

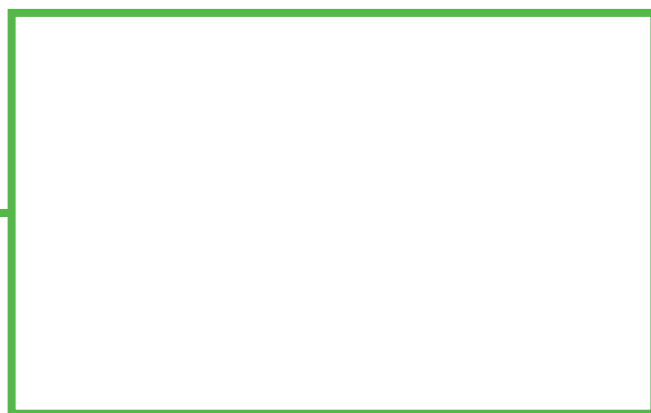

CMHE-CESAB MATERIAL HANDLING EUROPE - Version 1, 01-2026